

IPI10 Series Pneumatic-to-Current Converter

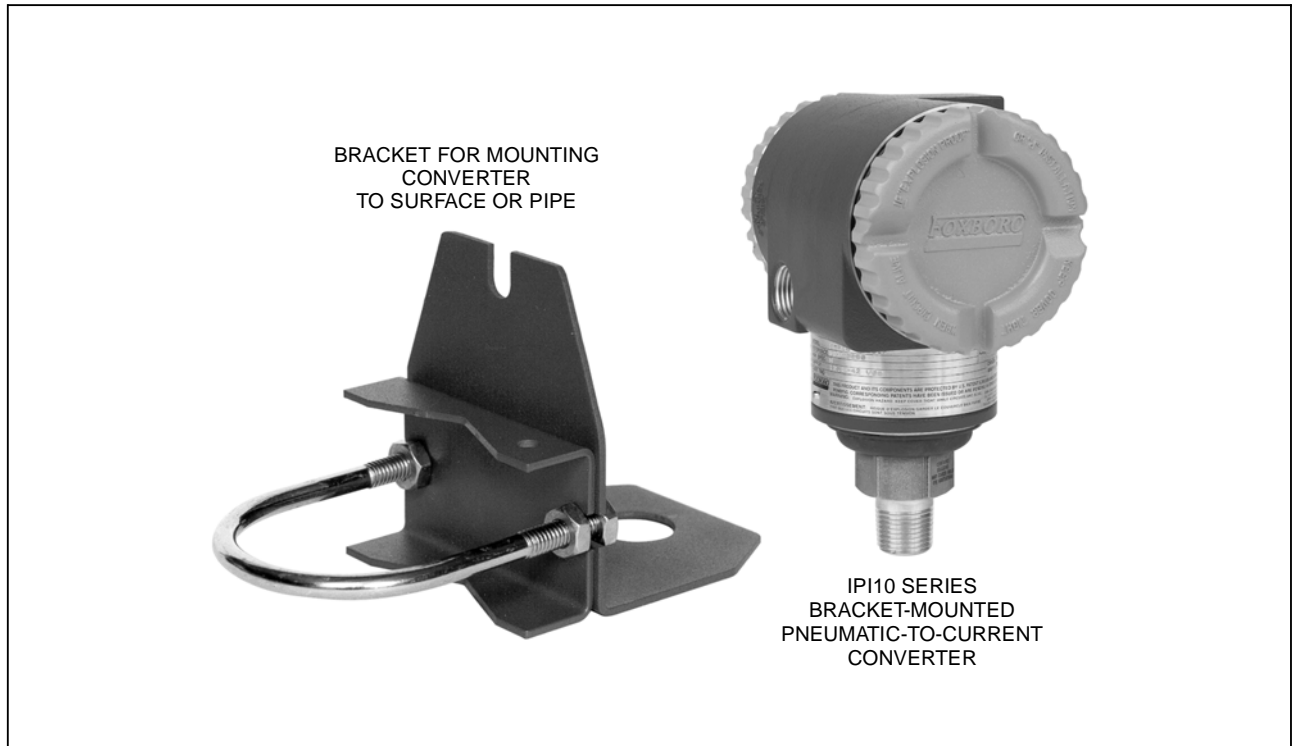

The IPI10 Series, Field-Mounted Pneumatic-to-Current Converters accept a pneumatic transmission input signal, and transmit a proportional 4 to 20 mA signal over conventional 2-wire transmission lines.

FEATURES

- Simple, Elegant Sensor Packaging uses very few Parts to achieve Exceptionally High Reliability
- Silicon Sensing Technology successfully Field-Proven in many Thousands of Installations
- Converter can be mounted to a Surface, or Horizontal and Vertical Pipe using the Mounting Bracket; an Internal 1/4 NPT is provided for the Input Connection
- LCD Indicator with On-Board Pushbuttons for Configuration and Calibration
- Aluminum Housing has Durable, Corrosion-Resistant Epoxy Finish; 316 ss Housing also Available; both meet NEMA 4X and IEC IP66
- Conforms with NAMUR Part 1 Interference Immunity Requirement (EMC)
- Complies with Electromagnetic Compatibility Requirements of European EMC Directive 89/336/EEC by Conforming to following CENELEC and IEC Standards: EN 50081-2, EN 50082-2, IEC 801-2 through 801-6
- Conforms to Applicable European Union Directives (Product Marked with "CE" Logo)
- Numerous Options and Accessories offered to expand the Capabilities of these Converters
- Standard 2-Year Warranty; 5-Year Optional

STANDARD LCD DIGITAL INDICATOR

A two-line digital indicator (Figure 1) with on-board pushbuttons is provided to allow zero and span adjustments as well as local configuration. The indicator is provided with a blind (solid) cover, or optionally with a window cover to allow for local viewing of input pressure in selected units or percent of range when in service.



Figure 1. Topworks with Standard LCD Indicator and Optional Window Cover

HIGH PERFORMANCE, VALUE, AND VERSATILITY

The IPI10 Converter is a high performance device that offers increased value and reliability for a wide variety of pneumatic-to-current conversions. It utilizes microprocessor-based correction to achieve both excellent accuracy and ambient temperature compensation. The lightweight and compact design promotes ease of installation or rapid replacement. In addition, spare-parts inventory and maintenance training is significantly minimized. Combine these features with the overrange, moisture, and radio-frequency interference (RFI) protection, and the result is a converter offering both great value and versatility.

MOUNTING FLEXIBILITY

The converter is supplied with a bracket for pipe or surface mounting and can be mounted in either the vertical or horizontal position. This variable mounting, coupled with its compact size and low weight, allows easy accessibility and overcomes most space restrictions.

EASE OF INSTALLATION

Rotatable Topworks allows converter installation in tight places, allows indicator to be positioned in preferred direction, and eases field retrofit.

Two Conduit Entrances offer a choice of entry positions for ease of installation and self-draining of condensation regardless of mounting position and topworks rotation.

Wiring Guides and Terminations provide ease of wire entry and support, plenty of space to work and store excess wire, and large, rugged, rugged screw terminals for easy wire termination.

OPERATING, STORAGE, AND TRANSPORTATION CONDITIONS

| Influence | Reference Operating Conditions | Normal Operating Conditions | Operative Limits | Storage and Transportation Limits |
|------------------------------|--------------------------------|--|-----------------------------------|--|
| Ambient Temperature (Note a) | 24 ±2°C (75 ±3°F) | -29 to + 82°C (-20 to +180°F) | -40 and +85°C (-40 and +185°F) | -54 and +85°C (-65 and +185°F) |
| Relative Humidity (Note b) | 50 ±10% | 0 to 100% | 0 and 100% | 0 and 100% Noncondensing |
| Supply Voltage | 30 ±0.5 V dc | 11.5 to 42 V dc(c) | 11.5 and 42 V dc(c) | Not Applicable |
| Output Load | 650 Ω | 0 to 1450 Ω | 0 and 1450 Ω | Not Applicable |
| Vibration | 1 m/s ² (0.1 “g”) | 6.3 mm (0.25 in) Double Amplitude: from 5 to 15 Hz with Aluminum Housing and from 5 to 9 Hz with 316 ss Housing ----- 0 to 30 m/s ² (0 to 3 “g”) from 15 to 500 Hz with Aluminum Housing; and 0 to 10 m/s ² (0 to 1 “g”) from 9 to 500 Hz with 316 ss Housing | | 11 m/s ² (1.1 “g”) from 2.5 to 5 Hz (in Shipping Package) |
| Mounting Position | Upright | Upright | No Limit | Not Applicable |

(a) Although the LCD will not be damaged at any temperature within the “Storage and Transportation Limits”, updates will be slowed and readability decreased at temperatures outside the Normal Operating Conditions.

(b) With topworks covers on and conduit entrances sealed.

(c) 11.5 V dc can be reduced to 11 V dc by using a plug-in shorting bar; see “Supply Voltage” and “Physical Specifications” sections.

PERFORMANCE SPECIFICATIONS

Zero-Based Calibrations; Under Reference Operating Conditions unless otherwise specified;
 URL = Upper Range Limit, and Span = Calibrated Span

Accuracy (includes Linearity, Hysteresis, and Repeatability)

±0.075% of Span

Stability

Long term drift is less than ±0.1% of URL over a 12 month period.

Supply Voltage Effect

Output changes less than 0.005% of span for each 1 V change within specified supply voltage requirements.

RFI Effect

The output error is less than 0.1% of span for radio frequencies in the range of 27 to 1000 MHz and field intensity of 30 V/m when the converter is properly installed with shielded conduit and grounding, and housing covers are in place. (Per IEC Std. 801-3.)

Position Effect

The converter may be mounted in any position. Any zero effect caused by the mounting position can be eliminated by rezeroing. There is no span effect.

Vibration Effect

Total effect: ±0.2% of URL per “g” for vibrations in the frequency range of 5 to 500 Hz; with double amplitudes of 6.35 mm (0.25 in) in the range of 5 to 15 Hz, or accelerations of 3 “g” in the range of 15 to 500 Hz, whichever is smaller, for aluminum housings; and with double amplitudes of 6.35 mm (0.25 in) in the range of 5 to 9 Hz, or accelerations of 1 “g” in the range of 9 to 500 Hz, whichever is smaller, for 316 ss housings.

Ambient Temperature Effect

Total effect for a 55°C (100°F) change within Normal Operating Condition limits is:

VERSION “-I” ELECTRONICS

±(0.155% URL + 0.1% Span)

VERSION “-A” ELECTRONICS

±(0.155% URL + 0.3% Span)

Switching and Indirect Lightning Transients

The converter can withstand a transient surge up to 2000 V common mode or 1000 V normal mode without permanent damage. The output shift is less than 1.0%. (Per ANSI/IEEE C62.41-1980 and IEC Std. 801-5.)

FUNCTIONAL SPECIFICATIONS

Input Signal

3 to 15 psi, 3 to 27 psi, 0.2 to 1.0 kg/cm², 20 to 100 kPa, or 0.2 to 1.0 bar, as specified.

Maximum Overrange Pressure

0.31 MPa, 45 psi, 3.15 bar or kg/cm²

Output Signal

4 to 20 mA dc, Linear

Supply Voltage Requirements and External Loop Load Limitations (Figure 2)

Nominal minimum supply voltage is 11.5 V dc. This value can be reduced 11 V dc by using a plug-in jumper across the test receptacles in field wiring compartment terminal block. Foxboro offers an optional plug-in shorting bar for this purpose (see Physical Specifications section).

Adjustable Damping

The converter response time is normally 1.0 s, or the electronically adjustable setting of 0 (none), 2, 4, or 8 seconds, whichever is greater, for a 90% recovery from an 80% input step per ANSI/ISA S51.1.

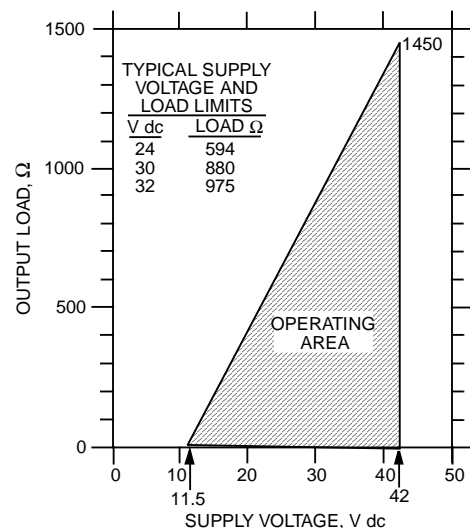

Figure 2. Supply Voltage vs. Output Load

Field Wiring Reversal

Accidental reversal of field wiring will not damage the converter.

Liquid Crystal Display (LCD) Indicator with On-Board Pushbuttons (Figure 3) Provides:

- Two lines; five numeric characters on top line (four when a minus sign is needed) and seven alphanumeric characters on bottom line.
- Measurement Readout; value on top line and units label on bottom line.
- Configuration and Calibration Prompts.

Zero and Span Adjustments

Accomplished using the on-board pushbuttons.

Optional External Zero Adjustment (Figure 3)

The optional pushbutton mechanism is isolated from the electronics compartment and magnetically activates an internal reed switch through the housing. This eliminates a potential leak path for moisture or contaminants to get into the electronics compartment. The external zero adjustment can be disabled by a configuration selection.

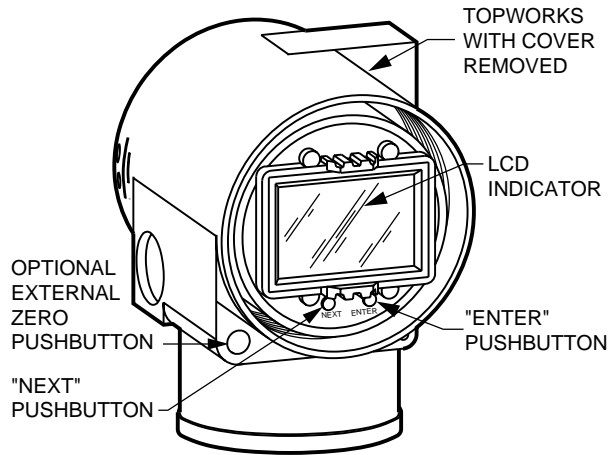

Figure 3. LCD Indicator with Pushbuttons

PHYSICAL SPECIFICATIONS

Measurement Side Material

316L ss (pneumatic connection and sensor diaphragm)

Reference Side Materials

Silicon, Pyrex, RTV, Ryton, and 316 ss (Atmospheric Reference)

Sensor Fill Fluid

Silicone Oil

Electronics Housing and Housing Covers

Housing has two compartments to separate the electronics from the field connections. The housing and covers are made from low copper, die-cast aluminum alloy with an epoxy finish, or from 316 ss. Buna-N O-rings are used to seal the threaded housing covers, housing neck, and terminal block.

Electronics Module

Printed wiring assemblies (PWAs) are conformally coated for moisture and dust protection.

Environmental Protection

Converter is dusttight and weather resistant per IEC IP66 and provides the environmental and corrosion resistant protection of NEMA Type 4X.

Mounting Bracket (Optional)

Low carbon steel with a painted gray finish. Used for mounting converter to a surface, or a nominal DN50 or 2-inch horizontal or vertical pipe.

Electrical Terminations

Field wires enter through 1/2 NPT or PG 13.5 threaded entrances on either side of the electronics housing. Wires terminate at a terminal block in the field terminal compartment, and the wire shield can terminate at the ground screw, as shown in Figure 4. Unused threaded entrance is plugged to ensure moisture and RFI/EMI protection.

Approximate Mass

1.5 kg (3.3 lb) with aluminum housing
Add 1.1 kg (2.4 lb) with 316 ss housing

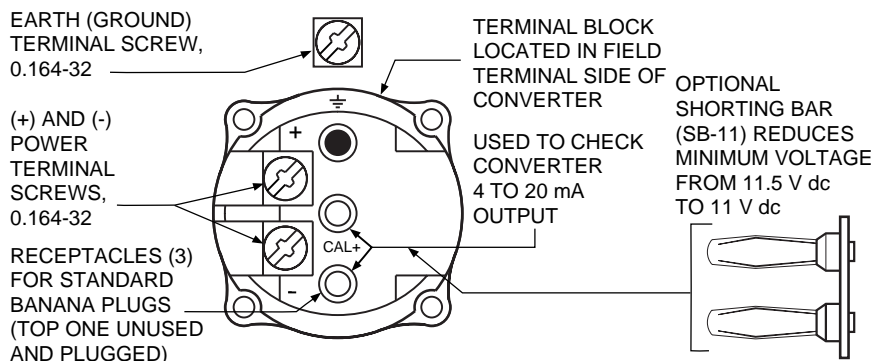

Figure 4. Field Terminal Connections

ELECTRICAL SAFETY SPECIFICATIONS

| Testing Laboratory, Types of Protection, and Area Classification | Application Conditions | Electrical Safety Code |
|--|--|------------------------|
| CENELEC EEx, ia, IIC. Intrinsically safe, Gas Group IIC, Zone 0. | Electronics Version “-I” Only. Temperature Class T4–T6. | E |
| CSA intrinsically safe for Class I, Division 1, Groups A, B, C, and D; Class II, Division 1, Groups E, F, and G; and Class III, Division 1. | Electronics Version “-I” Only. Connect per MI 020-427. Temperature Class T4A at 40°C (104°F), and T3C at 85°C (185°F) maximum ambient. | C |
| CSA explosionproof for Class I, Division 1, Groups B, C, and D; and dust-ignitionproof apparatus for Class II, Division 1, Groups E, F, and G; and Class III, Division 1. | Temperature Class T6 at 80°C (176°F) and T5 at 85°C (185°F) maximum ambient. | |
| CSA for Class I, Division 2, Groups A, B, C, and D; Class II, Division 2, Groups F and G; and Class III, Division 2 locations. | Connect to source not exceeding 42.4 V. Temperature Class T6 at 40°C (104°F) and T4A at 85°C (185°F) maximum ambient. | |
| European Ex, N, IIC. Nonsparking, Gas Group IIC, Zone 2. | Electronics Version “-I” Only. Temperature Class T4–T6. | N |
| FM intrinsically safe for Class I, Division 1, Groups A, B, C, and D; Class II, Division 1, Groups E, F, and G; and Class III, Division 1. | Electronics Version “-I” Only. Connect per MI 020-427. Temperature Class T4A at 40°C (104°F), and T4 at 85°C (185°F) maximum ambient. | F |
| FM explosionproof for Class I, Division 1, Groups B, C and D; and dust-ignitionproof apparatus for Class II, Division 1, Groups E, F, and G; and Class III, Division 1. | Temperature Class T6 at 80°C (176°F) and T5 at 85°C (185°F) maximum ambient. | |
| FM nonincendive apparatus for Class I, Division 2, Groups A, B, C, and D; Class II, Division 2, Groups F and G; and Class III, Division 2. | Connect to source not exceeding 42.4 V. Temperature Class T6 at 40°C (104°F) and T4A at 85°C (185°F) maximum ambient. | |
| SAA Ex, ia, IIC. Intrinsically safe, Gas Group IIC, Zone 0. | Electronics Version “-I” Only. Temperature Class T4. | H |
| SAA Ex, d, IIC. Flameproof, Gas Group IIC, Zone 1. | Temperature Class T6. | A |
| SAA Ex, n, IIC. Nonincendive, Gas Group IIC, Zone 2. | Temperature Class T6. | K |

NOTE

Converter has been designed to meet the electrical safety descriptions listed. Refer to Foxboro for information or status of testing laboratory approvals or certifications.

MODEL CODE

| Description | Model |
|---|--------------|
| Pneumatic-to-Current Converter | IPI10 |
| Electronics Version and Output Signal | |
| Electronic; 4 to 20 mA Analog Output | -A |
| Electronic; 4 to 20 mA Analog Output, Intrinsically Safe Design | -I |
| Input Signal | |
| 3 to 15 psi | 2 |
| 3 to 27 psi | 3 |
| 0.2 to 1.0 kg/cm ² | 4 |
| 20 to 100 kPa | 5 |
| 0.2 to 1.0 bar | 6 |
| Conduit Connections and Housing Material | |
| 1/2 NPT, Aluminum Housing | 1 |
| PG 13.5, Aluminum Housing (Available with Electrical Safety Codes "E", "N", and "H" only) | 2 |
| 1/2 NPT, 316 ss Housing | 3 |
| PG 13.5, 316 ss Housing (Available with Electrical Safety Codes "E", "N", and "H" only) | 4 |
| Electrical Safety (See Electrical Safety Specifications Section for Description and Approval Status) | |
| CENELEC Certified Intrinsically Safe, ia(a) | E |
| CSA Certified ia, d, and n(a) | C |
| European Certified Nonsparking, Ex, N, IIC (a) | N |
| FM Approved ia, d, and n(a) | F |
| SAA Certified Ex, ia, IIC(a) | H |
| SAA Certified Ex, d, IIC | A |
| SAA Certified Ex, n, IIC | K |
| Optional Selections | |
| Indicator with Pushbuttons | |
| Window Cover to allow Viewing of Internal LCD Indicator when in Service | -L3 |
| Conduit Connectors - Specify Only One | |
| Hawke-Type 1/2 NPT Cable Gland for use with Conduit Connection Codes "1" and "3"(b) | -A1 |
| Plastic PG 13.5 Cable Gland for use with Conduit Connection Codes "2" and "4"(c) | -A2 |
| M20 Connector for use with Conduit Connection Codes "1" and "3"(b) | -A3 |
| Brass PG 13.5 Cable Gland (Trumpet-Shaped) for use with Conduit Connection Codes "2" and "4"(c) | -A4 |
| Electronics Housing Features - Specify Only One | |
| External Zero Adjustment | -Z1 |
| Custody Transfer Lock and Seal | -Z2 |
| External Zero Adjustment and Custody Transfer Lock and Seal | -Z3 |
| Instruction Books (Paper Manual, and Full Documentation Set on CD is Standard) | |
| Without Instruction Book and CD ("Getting Started" document only) | -K1 |
| Full Instruction Book in Paper (d) | -K4 |
| Miscellaneous Optional Selections | |
| Five Year Warranty | -W |
| Supplemental Customer Tag (Stainless Steel Tag wired onto Transmitter) | -T |
| Without Mounting Bracket Assembly | -Y |
| Example: IPI10-I21F-L3T | |

(a) Converters with Electronics Version "-A" are not designed for Intrinsic Safety or European nonsparking.

(b) Available with Electrical Safety Codes "E", "N", and "H" only.

(c) Available with Electrical Safety Codes "E" and "H" only.

(d) Only the traditional Foxboro Paper Instruction Book (with all MIs, PL, DPs, etc.) is supplied.

SUGGESTED RFQ SPECIFICATIONS

The manufacturer shall provide a field-mounted pneumatic-to-current converter that accepts a pneumatic transmission input, and transmits a proportional 4 to 20 mA dc output signal over conventional 2-wire transmission lines. The specifications for this transmitter are:

| | |
|------------------------------------|--|
| Accuracy: | ±0.10% of span |
| Supply Voltage: | 11.5 to 42 V dc |
| Input Signal: | 3 to 15 psi, 3 to 27 psi, 0.2 to 1.0 kg/cm ² , 20 to 100 kPa, or 0.2 to 1.0 bar, as specified. |
| Pneumatic Input Connection: | 1/4 NPT, internal thread |
| Damping: | Settable for a range of none to 8 seconds. |
| RFI Protection: | The maximum error shall be no more than an additional ±0.1% of calibrated span for 30 V/m field intensity between 27 and 1000 MHz. |
| Housing: | Aluminum housing with Epoxy finish (or 316 ss). |
| Electronics: | Enclosed in a NEMA 4X (IEC IP66) housing sealed with O-rings for protection against moisture or other contaminants. |
| LCD Indicator: | Liquid Crystal Display (LCD) Indicator, with on-board pushbuttons for calibration and configuration; optional window cover for LCD viewing in service. |
| Modular Electronics: | Electronic modules shall be replaceable without requiring reconfiguration. |
| Mounting: | Direct mounting to a pneumatic transmitter; or mounting to a surface or pipe using a bracket. |
| Sensor and Fill Fluid: | 316L ss sensor with silicone fill fluid. |
| Electrical Classification: | Must be suitable for Division 1 Hazardous Locations. |
| Approximate Mass: | 1.5 kg (3.3 lb) with aluminum housing 2.6 kg (5.7 lb) with 316 ss housing |
| Model Code: | Foxboro IPI10 Series Pneumatic-to-Current Converters, for either Explosionproof applications, or both Explosionproof and Intrinsically Safe applications; or equivalent. |

ORDERING INSTRUCTIONS

1. Model Number
2. Optional Features not included in Model Number
3. Tag and Application

DIMENSIONS - NOMINAL

**mm
in**

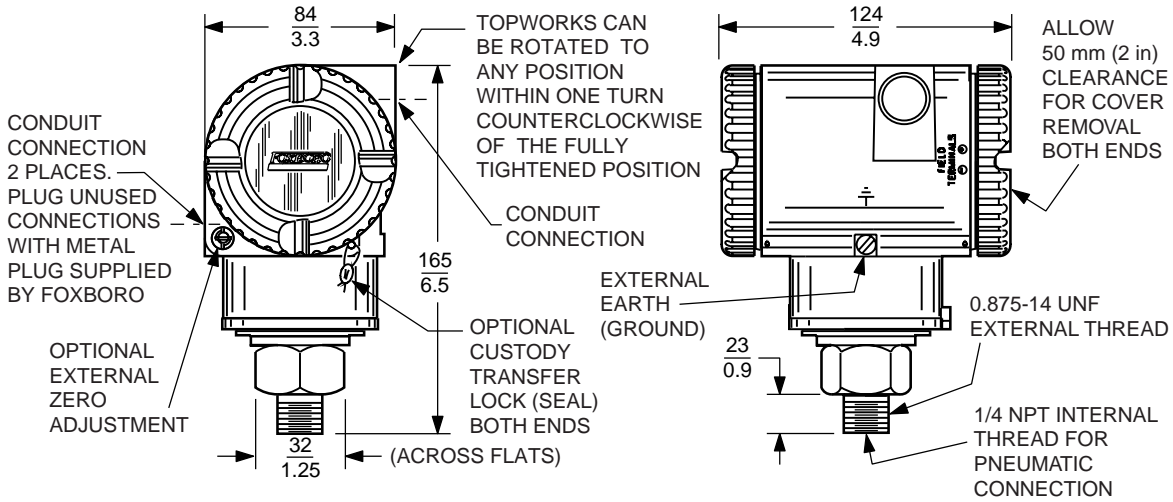

PIPE AND SURFACE MOUNTING WITH BRACKET ASSEMBLY

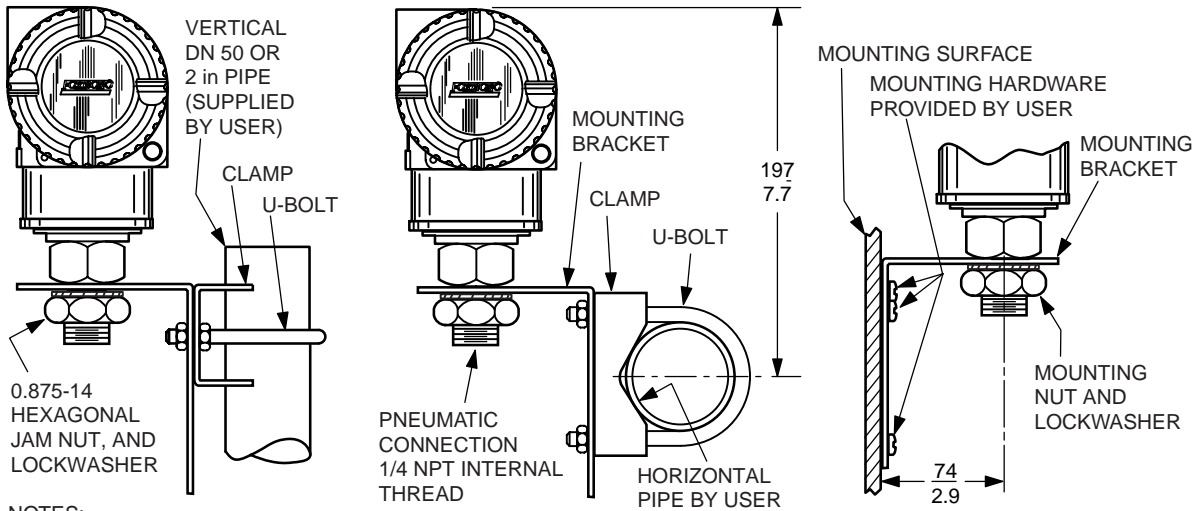

NOTES:

1. Clamp and U-bolt nut required in surface mounting applications.
2. Do not use 1/4 NPT internal thread to direct-mount the converter.
3. Refer to DP 020-414 for further dimensional information.

The Foxboro Company
33 Commercial Street
Foxboro, MA 02035-2099
United States of America
<http://www.foxboro.com>
Inside U.S.: 1-888-FOXBORO
(1-888-369-2676)
Outside U.S.: Contact your local
Foxboro representative.
Facsimile (508) 549-4492

Foxboro and I/A Series are registered trademarks of The Foxboro Company.
FOUNDATION is a trademark of The Fieldbus Foundation.
Pyrex is a trademark of Corning Glass.
Ryton is a trademark of Phillips Petroleum Co.

Copyright 2000 by The Foxboro Company
All rights reserved

An Invensys company

MB 010

Printed in U.S.A.

0100